

SFP28 BIDI 10km C-temp Transceiver

APS8BxxB53CDL10

■ Product Features

- ✓ Signal LC connector
- ✓ Hot-pluggable SFP28 footprint
- ✓ Operating data rate up to 25.78Gbps
- ✓ Uncooled 1270/1330nm DFB laser
- ✓ RoHS compliant and Lead Free
- ✓ Distance up to 10Km on 9/125um SMF
- ✓ Metal enclosure for lower EMI
- ✓ Power dissipation <1.2W (0~70°C)
- ✓ Commercial operating temperature optional



■ Applications

- ✓ CPRI Option 10
- ✓ 25GBE

■ General

ATOP's APS8BxxB53CDL10 single-mode transceiver is SFP28 module for duplex optical data communications support up to 25.78Gb/s. It is with the SFP+ 20-pin connector to allow hot plug capability. Digital diagnostic functions are available via an I²C. It has built-in clock and data recovery (CDR). This module is designed for single-mode fiber and operates at a nominal wavelength of 1270 / 1330nm.

■ Product Selection

Part Number	Wavelength	Operating Case temperature
APS8B23B53CDL10	Tx-1270 / Rx-1330	Commercial
APS8B32B53CDL10	Tx-1330 / Rx-1270	Commercial

■ Regulatory Compliance

- ESD to the Electrical PINs: compatible with MIL-STD-883 Method 3015
- ESD to the Signal LC Receptacle: compatible with IEC 61000-4-2
- Immunity compatible with IEC 61000-4-3
- EMI compatible with FCC Part 15 Class B EN55022 Class B (CISPR 22B) VCCI Class B



- Laser Eye Safety compatible with FDA 21CFR 1040.10 and 1040.11 EN60950, EN (IEC) 60825-1,2
- RoHS compliant with RoHS 2 (2011/65/EU)

Pin Descriptions

Pin	Symbol	Name/Description	Ref.
1	VeeT	Transmitter Ground (Common with Receiver Ground)	1
2	TX Fault	Transmitter Fault. LVTTTL-O	2
3	TX Disable	Transmitter Disable. Laser output disabled on high or open. LVTTTL-I	3
4	SDA	2-Wire Serial Interface Data Line (Same as MOD-DEF2 in INF-8074i). LVTTTL-I/O	2
5	SCL	2-Wire Serial Interface Data Line (Same as MOD-DEF2 in INF-8074i). LVTTTL-I	2
6	Mod_ABS	Module Absent, Connect to VeeT or VeeR in Module.	2
7	RS0	Rate Select 0, optionally controls SFP+ module receiver LVTTTL-I	4
8	LOS	Loss of Signal indication. Logic 0 indicates normal operation. LVTTTL-O	5
9	RS1	Rate Select 1, optionally controls SFP+ module transmitter. LVTTTL-I	4
10	VeeR	Receiver Ground (Common with Transmitter Ground)	1
11	VeeR	Receiver Ground (Common with Transmitter Ground)	1
12	RD-	Receiver Inverted DATA out. AC Coupled. CML-O	
13	RD+	Receiver Non-inverted DATA out. AC Coupled. CML-O	
14	VeeR	Receiver Ground (Common with Transmitter Ground)	1
15	VccR	Receiver Power Supply	6
16	VccT	Transmitter Power Supply	6
17	VeeT	Transmitter Ground (Common with Receiver Ground)	1
18	TD+	Transmitter Non-Inverted DATA in. AC Coupled. CML- I	
19	TD-	Transmitter Inverted DATA in. AC Coupled. CML- I	

20	VeeT	Transmitter Ground (Common with Receiver Ground)	1
----	------	--	---

Notes:

1. Circuit ground is internally isolated from chassis ground.
2. TX Fault is an open collector/drain output .Which should be pulled up with a 4.7K – 10K Ohms resistor on the host board if intended for use. Pull up voltage should be between 2.0V to Vcc+0.3V.A high output indicates a transmitter fault caused by either the tx bias current or the tx output power exceeding the preset alarm thresholds. A low output indicates normal operation .In the low state, the output is pulled to <0.8V.
3. Laser output disabled on TX Disable >2.0V or open, enabled on TX Disable<0.8V.
4. Internally pulled down per SFF-8431 Rev4.1.
5. LOS is open collector output. Should be pulled up with 4.7k – 10kohms on host board to a voltage between 2.0V and 3.6V. Logic 0 indicates normal operation; logic 1 indicates loss of signal.
6. Internally connected

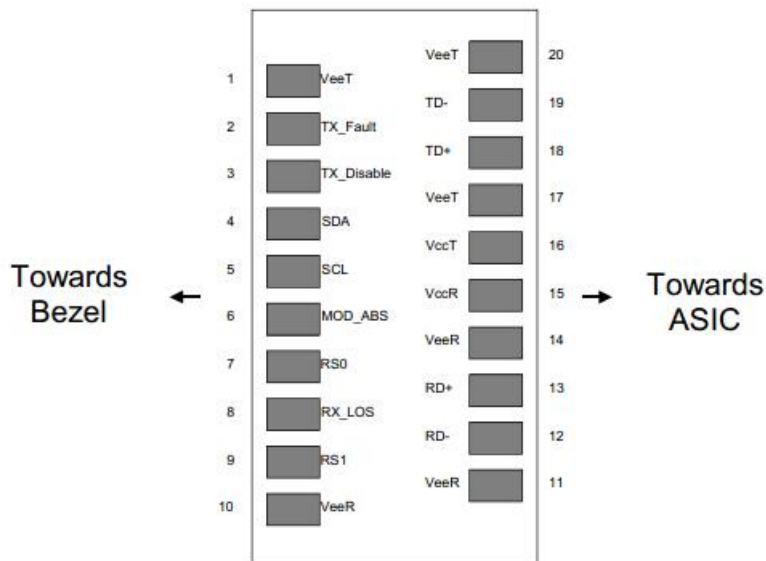

Pin-out of Connector Block on Host Board

■ **Recommend Circuit Schematic**

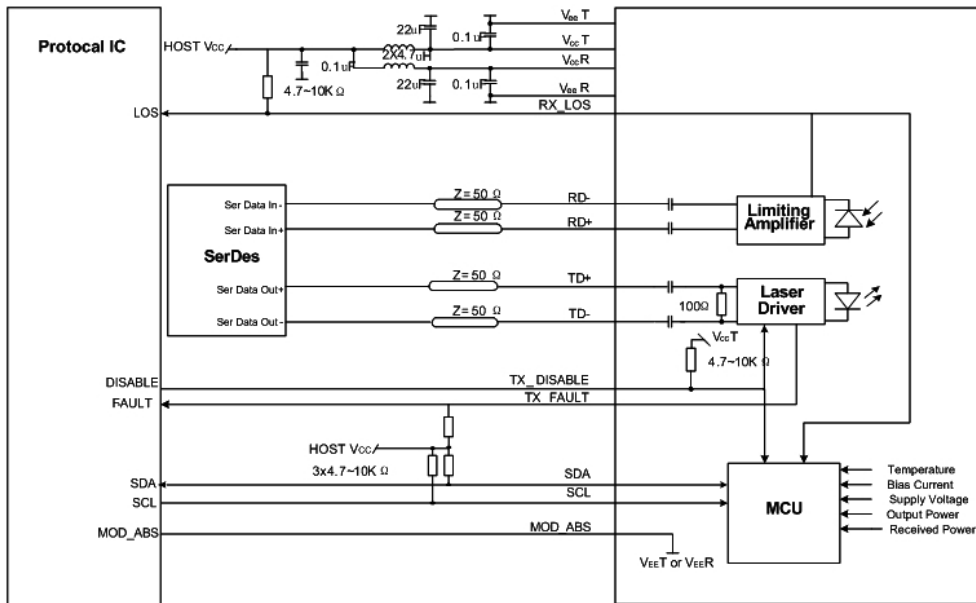

■ **Absolute Maximum Ratings**

Parameter	Symbol	Min	Typ	Max	Unit	Ref.
Maximum Supply Voltage	Vcc	-0.5		+4.0	V	
Storage Temperature	TS	-40		+85	°C	
Operating Humidity	RH	0		85	%	

■ **Recommended Operating Conditions**

Parameter	Symbol	Min	Typ	Max	Unit	Ref.
Power Supply Voltage	Vcc	3.13	3.30	3.47	V	
Power Supply Current	Icc			360	mA	Commercial
Case Operating Temperature	Tc	0		+70	°C	Commercial
Data Rate(Gigabit Ethernet)	BR			25.78	Gbps	
9/125um G.652 SMF	Lmax			10	km	



■ **Electrical Characteristics (TOP=25°C, Vcc=3.3Volts)**

Parameter	Symbol	Min	Typ	Max	Unit	Ref.
Transmitter						
Input Differential Impedance	Rin	90	100	110	Ω	1
Differential Data Input Swing	Vin, pp	120		850	mV	
TX Disable-High		Vcc-1.3		Vcc+0.3	V	
TX Disable-Low		Vee		Vee+0.8	V	
TX Fault-High		2		Vcc+0.3	V	
TX Fault-Low		0		0.8	V	
Receiver						
Differential Data Input Swing	Vout, pp	300		850	mV	2
LOS-High		2.4		Vcc+0.3	V	
LOS-Low		0		0.8	V	

Notes:

1. AC coupled.
2. Into 100 ohm differential termination.

■ **Optical Characteristics (TOP=25°C, Vcc=3.3 Volts)**

Parameter	Symbol	Min	Typ	Max	Unit	Note
Transmitter						
Output Opt. Power	PO	-7		+2	dBm	
Optical Wavelength	λ	1260	1270	1280	nm	
		1320	1330	1340	nm	
Side-Mode Suppression Ratio	SMSR	30			dB	
Spectral Width(-20dB)	Δλ			1	nm	
Optical Extinction Ratio	ER	3.5			dB	
Receiver						
RX Sensitivity @25.78Gb/s	SEN			-12.5	dBm	1
RX Sensitivity OMA@25.78Gb/s	SEN			-10.6	dBm	1

Receiver Overload		2			dBm	
Optical Center Wavelength	λ C	1320	1330	1340	nm	
		1260	1270	1280	nm	
LOS De-Assert	LOSD			-16	dBm	
LOS Assert	LOSA	-30			dBm	
LOS Hysteresis		0.5		5	dB	

Notes:

1. Measured with data rate at 25.78Gb/s, BER less than 1E-12 with PRBS 2³¹-1.

■ Mechanical Specifications

ATOP's Small Form Factor Pluggable (SFP28) transceivers are compatible with the dimensions defined by the SFP Multi-Sourcing Agreement (MSA), dimensions are in mm.

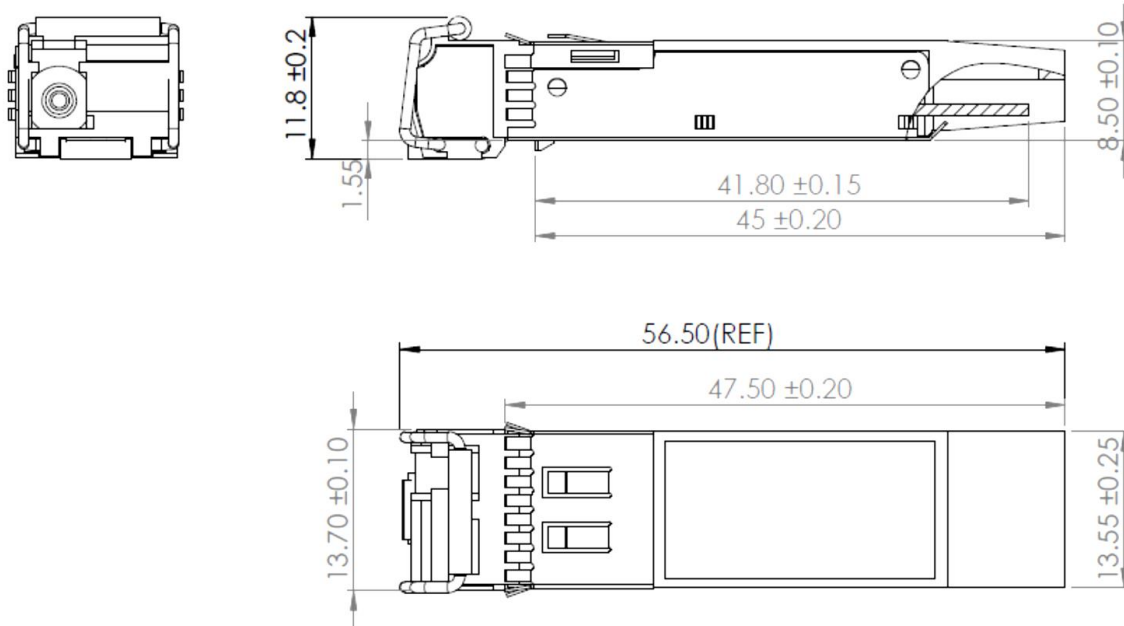

APS8BxxB53CDL10

■ EEPROM Information

EEPROM memory map specific data field description is as below:

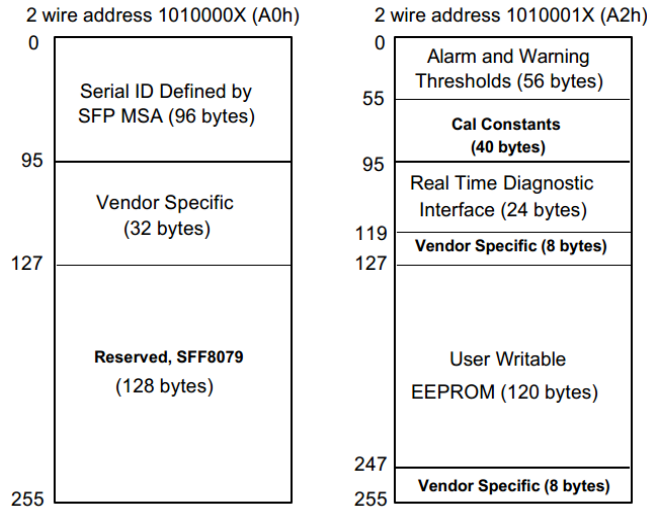

■ Digital Diagnostic Monitoring Interface

Five transceiver parameter values are monitored. The following table defines the monitored parameter's accuracy.

Parameter	Range	Accuracy	Calibration
Temperature	0 to +70°C (C)	±3°C	Internal
Voltage	2.97 to 3.63V	±3%	Internal
Bias Current	0 to 100mA	±10%	Internal
TX Power	-7 to +2dBm	±3dB	Internal
RX Power	-15 to +2dBm	±3dB	Internal

■ Revision History

Revision	Initiated	Reviewed	Approved	DCN	Release Date
Version1.0	Colin.Huang	Tangzhiqiang	Dingzheng	New Released.	Dec 15, 2018

■ For More Information

ATOP Corporation

Tel: +86-755-86674946

Fax: +86-755-86296723

Email: sales@atoptechnology.com

Web: www.atoptechnology.com