

10.3Gb/s XFP Transceiver

APXDxxHM0xDL40

■ Product Features

- ✓ Supports 9.95 to 11.3Gb/s
- ✓ Duplex LC connector
- ✓ Hot-pluggable XFP footprint
- ✓ Cooled 1550nm EML laser
- ✓ RoHS compliant and Lead Free
- ✓ 40Km link length
- ✓ Metal enclosure for lower EMI
- ✓ 100GHz channel spacing
- ✓ Built-in dual CDR
- ✓ +5.0V and +3.3V power supply and power dissipation <2.5W
- ✓ XFP MSA INF-8077I Compliant
- ✓ XFI loop-back Support



■ Applications

- ✓ SONET OC-192 IR-2/IR-3
- SDH STM S-64.2b/S-64.3b
- ITU-T G.709
- ✓ IEEE 802.3ae 10GBASE-ER/
EW 40km 10G Ethernet
- ✓ Supports OTN/1TU-T G.709
- ✓ DWDM point-to-point link

■ General

ATOP's APXDxxHM0xDL40 Small Form Factor 10Gb/s XFP transceivers are compatible with XFP MSA Specification. They comply with SONET OC-192 IR-2,OC-192 IR-3,SDH STM S-64.2b,STM S-64.3b as well as with 10G Ethernet 10G BASE-ER/EW per IEEE802.3ae and 40km 10G Fibre Channel applications.

■ Product Selection

Part Number	Operating Case temperature	DDMI
APXDxxHM0CDL40	Commercial(0~70°C)	Yes
APXDxxHM0EDL40	Extend(0~85°C)	Yes
APXDxxHM0IDL40	Industrial(-40~85°C)	Yes

■ Product Channel Selection



APXDxxHM0xDL40

Product Code	ITU channel	Frequency	Center Wavelength(nm)
APXD61HM0xDL40	61	196.1	1528.77
APXD60HM0xDL40	60	196.0	1529.55
APXD59HM0xDL40	59	195.9	1530.33
APXD58HM0xDL40	58	195.8	1531.12
APXD57HM0xDL40	57	195.7	1531.90
APXD56HM0xDL40	56	195.6	1532.68
APXD55HM0xDL40	55	195.5	1533.47
APXD54HM0xDL40	54	195.4	1534.25
APXD53HM0xDL40	53	195.3	1535.04
APXD52HM0xDL40	52	195.2	1535.82
APXD51HM0xDL40	51	195.1	1536.61
APXD50HM0xDL40	50	195.0	1537.40
APXD49HM0xDL40	49	194.9	1538.19
APXD48HM0xDL40	48	194.8	1538.98
APXD47HM0xDL40	47	194.7	1539.77
APXD46HM0xDL40	46	194.6	1540.56
APXD45HM0xDL40	45	194.5	1541.35
APXD44HM0xDL40	44	194.4	1542.14
APXD43HM0xDL40	43	194.3	1542.94
APXD42HM0xDL40	42	194.2	1543.73
APXD41HM0xDL40	41	194.1	1544.53
APXD40HM0xDL40	40	194.0	1545.32
APXD39HM0xDL40	39	193.9	1546.12
APXD38HM0xDL40	38	193.8	1546.92
APXD37HM0xDL40	37	193.7	1547.72
APXD36HM0xDL40	36	193.6	1548.51
APXD35HM0xDL40	35	193.5	1549.32
APXD34HM0xDL40	34	193.4	1550.12

**APXDxxHM0xDL40**

APXD33HM0xDL40	33	193.3	1550.92
APXD32HM0xDL40	32	193.2	1551.72
APXD31HM0xDL40	31	193.1	1552.52
APXD30HM0xDL40	30	193.0	1553.33
APXD29HM0xDL40	29	192.9	1554.13
APXD28HM0xDL40	28	192.8	1554.94
APXD27HM0xDL40	27	192.7	1555.75
APXD26HM0xDL40	26	192.6	1556.55
APXD25HM0xDL40	25	192.5	1557.36
APXD24HM0xDL40	24	192.4	1558.17
APXD23HM0xDL40	23	192.3	1558.98
APXD22HM0xDL40	22	192.2	1559.79
APXD21HM0xDL40	21	192.1	1560.61
APXD20HM0xDL40	20	192.0	1561.42
APXD19HM0xDL40	19	191.9	1562.23
APXD18HM0xDL40	18	191.8	1563.05
APXD17HM0xDL40	17	191.7	1563.86

Regulatory Compliance

- ESD to the Electrical PINs: compatible with MIL-STD-883 Method 3015
- ESD to the Duplex LC Receptacle: compatible with IEC 61000-4-2
- Immunity compatible with IEC 61000-4-3
- EMI compatible with FCC Part 15 Class B EN55022 Class B (CISPR 22B) VCCI Class B
- Laser Eye Safety compatible with FDA 21CFR 1040.10 and 1040.11 EN60950, EN (IEC) 60825-1,2
- ROHS compliant with ROHS 2 (2011/65/EU)

Pin Descriptions

Pin	Symbol	Name/Description	Ref.
1	GND	Module Ground	
2	VEE5	Optional -5.2 Power Supply – Not required	



3	MOD_DESEL	Module De-select; When held low allows the module to respond to 2-wire serial interface. LVTTTL-I	
4	/INTERRUPT	Interrupt; Indicates presence of an important condition which can be read via the 2-wire serial interface. LVTTTL-O	2
5	TX_DIS	Transmitter Disable. Logic1 indicates laser output disabled, LVTTTL-I	
6	VCC5	+5V Power Supply	
7	GND	Module Ground	1
8	VCC3	+3.3V Power Supply	
9	VCC3	+3.3V Power Supply	
10	SCL	2-Wire Serial Interface Clock. LVTTTL-I	2
11	SDA	2-Wire Serial Interface Data Line. LVTTTL-I/O	2
12	MOD_Abs	Indicates Module is not present. Grounded in the Module. LVTTTL-O	2
13	MOD_NR	Module Not Ready; Indicating Module Operational Fault. Open-collector. LVTTTL-O	2
14	RX_LOS	Loss of Signal indication. Logic 1 indicates loss of Signal. Open-collector. LVTTTL-O	2
15	GND	Module Ground	1
16	GND	Module Ground	1
17	RD-	Receiver Inverted Data Output. CML-O	
18	RD+	Receiver Non-Inverted Data Output. CML-O	
19	GND	Module Ground	1
20	VCC2	+1.8V Power Supply (Not required).	3
21	P_DOWN/RESET	Power down; When high, requires the module to limit power consumption to 1.5W or below. 2-Wire serial interface must be functional in the low power mode. LVTTTL-I	
		Reset; The falling edge initiates a complete reset of the module including the 2-wire serial interface, equivalent to a power cycle. LVTTTL-I	

22	VCC2	+1.8V Power Supply (Not required)	3
23	GND	Module Ground	1
24	REFCLK+	Reference Clock (Not required)	
25	REFCLK-	Reference Clock (Not required)	
26	GND	Module Ground	1
27	GND	Module Ground	1
28	TD-	Transmitter Inverted Data Input. CML-I	
29	TD+	Transmitter Non-Inverted Data Input. CML-I	
30	GND	Module Ground	1

Notes:

1. Module ground pins GND are isolated from the module case and chassis ground within the module.
2. Open collector; Should be pulled up with 4.7K-10Kohms to a voltage between 3.15V and 3.6V on the host board.
3. The pins are open within module.

■ **Pin-out Connector Block on Host Board**

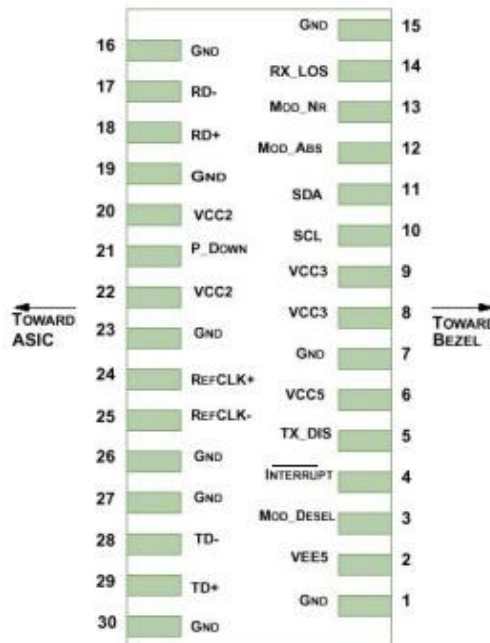

Pin-out of Connector Block on Host Board

■ **Recommend Circuit Schematic**

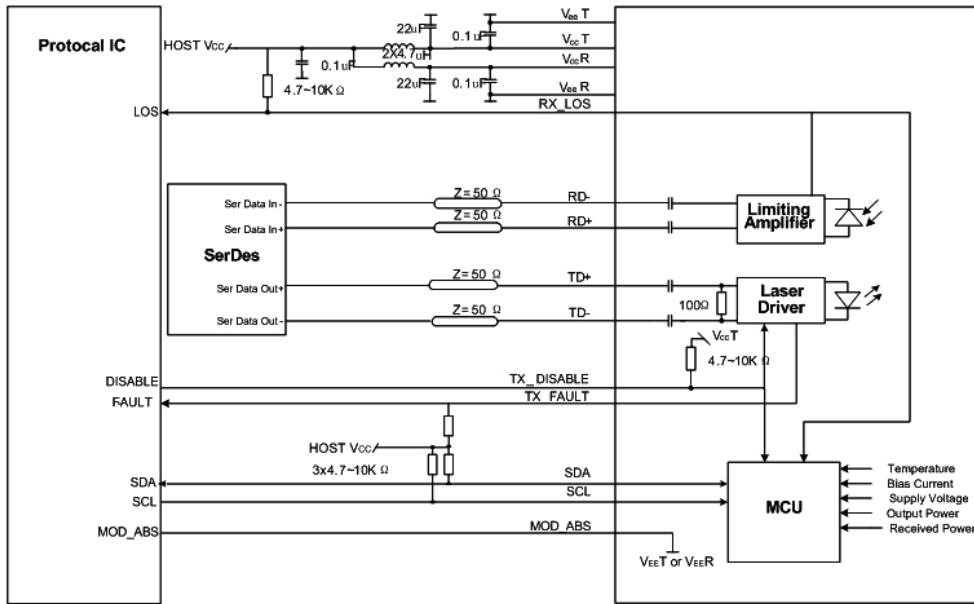

Absolute Maximum Ratings

Parameter	Symbol	Min	Typ	Max	Unit	Ref.
Maximum Supply Voltage	Vcc3	-0.5		+4.0	V	
	Vcc5	-0.5		+6.0	V	
Storage Temperature	TS	-40		+85	°C	
Operating Humidity	RH	0		85	%	

Recommended Operating Conditions

Parameter	Symbol	Min	Typ	Max	Unit	Ref.
Power Supply Voltage	Vcc3	3.13	3.30	3.47	V	
	Vcc5	4.75	5.0	5.25	V	
Power Supply Current	Icc3			600	mA	
	Icc5			100	mA	
Case Operating Temperature	Tc	0		+70	°C	Commercial
	Te	0		+85		Extend
	Tl	-40		+85		Industrial
Bit Rate	Br	9.95		11.3	Gbps	
9/125um G.652 SMF	Lmax			40	km	

Electrical Characteristics (TOP=25°C, Vcc3=3.3Volts)



APXDxxHM0xDL40

Parameter	Symbol	Min	Typ	Max	Unit	Ref.
Transmitter						
Input differential impedance	Rin	80	100	120	Ω	1
Differential data input swing	Vin, pp	120		850	mV	
TX Disable-High		Vcc – 0.8		Vcc	V	
TX Disable-Low		Vee		Vee+ 0.8	V	
TX Fault-High		Vcc-0.8		Vcc	V	
TX Fault-Low		Vee		Vee+0.8	V	
Receiver						
Single ended data output swing	Vout, pp	300		850	mV	2
Data output rise time	Tr	30			ps	3
Data output fall time	Tf	30			ps	3
LOS-High		Vcc – 0.8		Vcc	V	
LOS-Low		Vee		Vee+0.8	V	

Notes:

1. AC coupled.
2. Into 100 ohm differential termination.
3. 20 – 80 %

Optical Characteristics (TOP=25°C, Vcc3=3.3 Volts)

Parameter	Symbol	Min	Typ	Max	Unit	Ref.
Transmitter						
Output Opt. Power	PO	-1		4	dBm	
Optical Wavelength	λ	As per ITU-T 694.1			nm	
Side-Mode Suppression Ratio	SMSR	30			dB	
RMS Spectral Width(-20dB)	σ			1	nm	
Optical Extinction Ratio	ER	8.2			dB	
Tx Jitter(SONET)20KHZ-80MHZ	Txj1			0.3	UI	3
Tx Jitter(SONET)4MHZ-80MHZ	TXj2			0.1	UI	3
Path penalty at 800ps/nm@9.95Gb/s				2	dB	



APXDxxHM0xDL40

Relative Intensity Noise	RIN			-128	dB/Hz	
Center Wavelength	λ_c EOL	z-100	z	Z+100	pm	
Receiver						
RX Sensitivity @10.3 Gb/s	SENS			-16	dBm	1,2
Receiver Overload		-1			dBm	
Optical Center Wavelength	λ_c	1260		1600	nm	
LOS De-Assert	LOSD			-20	dBm	
LOS Assert	LOSA	-34			dBm	
LOS Hysteresis		0.5			dB	
Rx Noise-Limited Performance(OSNR)						
Bit Rate(Gb/s)	Max CD (ps/nm)	BER-		Max OSNR (dB)		REF
8.5,9.95-10.3	0	1E-12	OSNR1	26	4	
	800		OSNR2	26	4	
10.7-11.3	0	1E-04	OSNR5	21	4	
	800		OSNR6	21	4	

Notes:

1. Measured with conformance signals defined in FC-PI-2 Rev. 10.0 specifications.
2. Measured with PRBS 231-1 at 10-12 BER.
3. GR-253-CORE Issue 4.
4. With optical input power at the receiver between -1 ~ -11dBm.

■ **Mechanical Specifications**

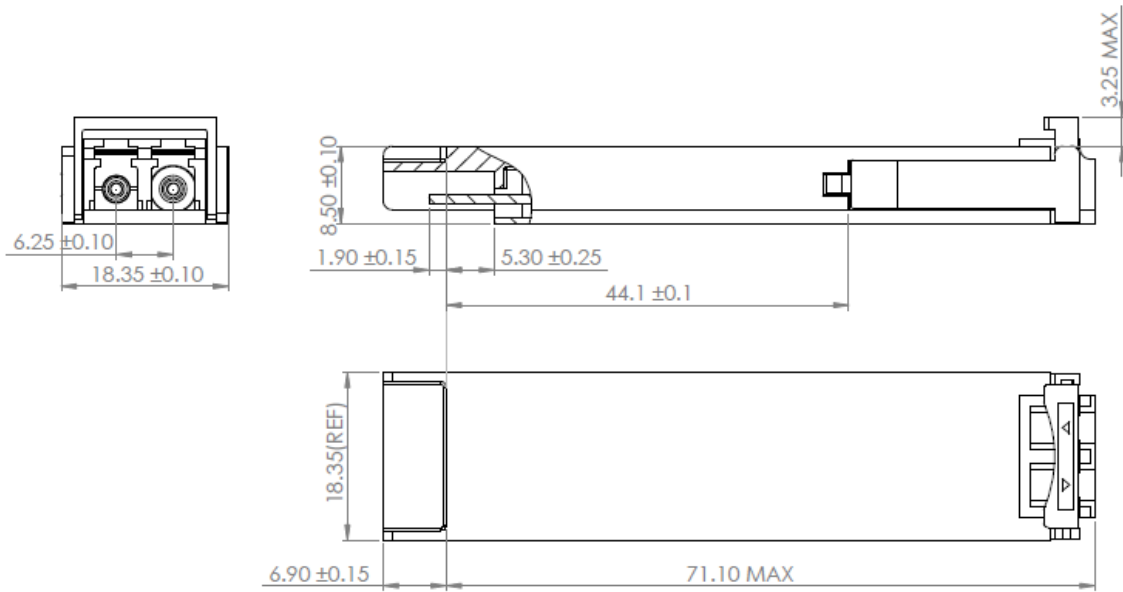

APXDxxHM0xDL40

■ **EEPROM Information**

EEPROM memory map specific data field description is as below:

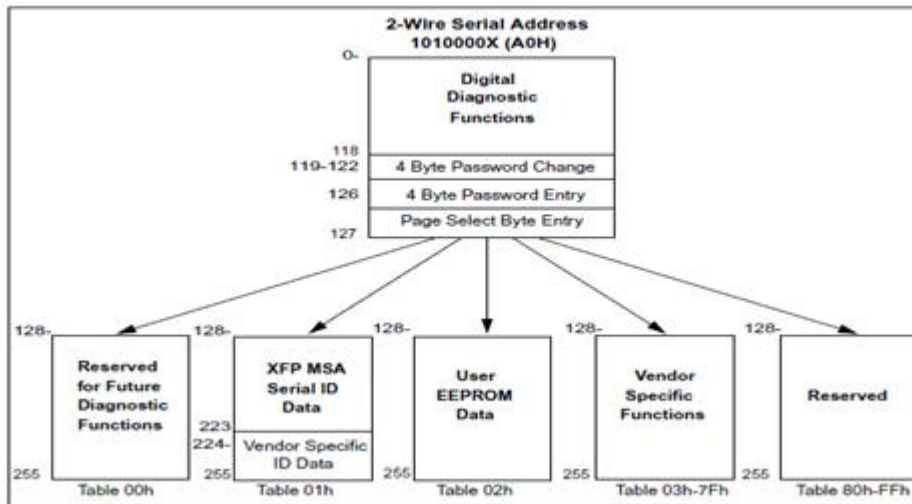

■ **Digital Diagnostic Monitoring Interface**

Five transceiver parameter values are monitored. The following table defines the monitored parameter's accuracy.

Parameter	Range	Accuracy	Calibration
-----------	-------	----------	-------------



APXDxxHM0xDL40

Temperature	0 to +70°C (C)	±3°C	Internal
	0 to +85°C (E)		
	-40 to +85°C (I)		
Voltage	2.97 to 3.63V	±3%	Internal
Bias Current	0 to 100mA	±10%	Internal
TX Power	-1 to 4dBm	±3dB	Internal
RX Power	-16 to -1dBm	±3dB	Internal

■ Revision History

Revision	Initiated	Reviewed	Approved	DCN	Release Date
V1.0	xiaoaiyou	wangqiang		New Released.	July 28, 2016

■ For More Information

ATOP Corporation

Tel: +86-755-86674946

Fax: +86-755-86296723

Email: sales@atoptechnology.com

Web: www.atoptechnology.com