



# 10.3Gb/s SFP+ Transceiver

APSPCxxB33CDL20



# 10.3Gb/s SFP+ Transceiver

## APSPCxxB33CDL20

ATOP's APSPCxxB33CDL20 Small Form Factor Pluggable (SFP+) transceivers are compatible with SFF-8431, SFF-8432 and support 10GBASE Ethernet and 10G Fibre Channel. It is designed for use in 10G-Gigabit multi-rate links up to 10km of G.652. Digital diagnostics functions are available via a 2-wire serial interface, as specified in SFF-8472.

### Product Features

- ✓ Duplex LC connector
- ✓ Hot-pluggable SFP footprint
- ✓ CWDM DFB transmitter
- ✓ RoHS compliant and Lead Free
- ✓ Distance up to 20km on 9/125um SMF
- ✓ Metal enclosure for lower EMI
- ✓ Power dissipation <1.0W
- ✓ Commercial operating temperature optional
- ✓ SFP MSA SFF-8472 SFF-8431 SFF-8432 Compliant

### Applications

- ✓ 10GBASE Ethernet
- ✓ 10G Fibre Channel



## Product Selection

Part Number	Operating Case temperature	Tx Wavelength
APSPC27B33CDL20	Commercial(0~70°C)	1270nm
APSPC29B33CDL20	Commercial(0~70°C)	1290nm
APSPC31B33CDL20	Commercial(0~70°C)	1310nm
APSPC33B33CDL20	Commercial(0~70°C)	1330nm
APSPC35B33CDL20	Commercial(0~70°C)	1350nm
APSPC37B33CDL20	Commercial(0~70°C)	1370nm

## Regulatory Compliance

- ESD to the Electrical PINs: compatible with MIL-STD-883 Method 3015
- ESD to the Duplex LC Receptacle: compatible with EN 61000-4-2
- Immunity compatible with EN 61000-4-3
- EMI compatible with FCC Part 15 Class B
- Laser Eye Safety compatible with FDA 21CFR 1040.10 and 1040.11 IEC 60950, IEC 60825-1,2
- RoHS compliant with RoHS 2.0 (2015/863/EU)-amending

## Pin Descriptions

Pin	Symbol	Name	Ref.
1	VeeT	Transmitter Ground (Common with Receiver Ground)	1
2	TX Fault	Transmitter Fault. LVTTTL-O	2
3	TX Disable	Transmitter Disable. Laser output disabled on high or open. LVTTTL-I	3
4	SDA	2-Wire Serial Interface Data Line (Same as MOD-DEF2 in INF-8074i). LVTTTL-I/O	2
5	SCL	2-Wire Serial Interface Data Line (Same as MOD-DEF2 in INF-8074i). LVTTTL-I	2
6	Mod_ABS	Module Absent, Connect to VeeT or VeeR in Module.	2
7	RS0	Rate Select 0, optionally controls SFP+ module receiver LVTTTL-I	4
8	LOS	Loss of Signal indication. Logic 0 indicates normal operation. LVTTTL-O	5
9	RS1	Rate Select 1, optionally controls SFP+ module transmitter. LVTTTL-I	4
10	VeeR	Receiver Ground (Common with Transmitter Ground)	1
11	VeeR	Receiver Ground (Common with Transmitter Ground)	1
12	RD-	Receiver Inverted DATA out. AC Coupled. CML-O	
13	RD+	Receiver Non-inverted DATA out. AC Coupled. CML-O	
14	VeeR	Receiver Ground (Common with Transmitter Ground)	1
15	VccR	Receiver Power Supply	6
16	VccT	Transmitter Power Supply	6
17	VeeT	Transmitter Ground (Common with Receiver Ground)	1
18	TD+	Transmitter Non-Inverted DATA in. AC Coupled. CML- I	
19	TD-	Transmitter Inverted DATA in. AC Coupled. CML- I	
20	VeeT	Transmitter Ground (Common with Receiver Ground)	1

## Note

1. Circuit ground is internally isolated from chassis ground.
2. TX Fault is an open collector/drain output .Which should be pulled up with a 4.7K – 10K Ohms resistor on the host board if intended for use. Pull up voltage should be between 2.0V to Vcc+0.3V.A high output indicates a transmitter fault caused by either the tx bias current or the tx output power exceeding the preset alarm thresholds. A low output indicates normal operation .In the low state, the output is pulled to <math><0.8V</math>.
3. Laser output disabled on TX Disable >2.0V or open, enabled on TX Disable<math><0.8V</math>.
4. Internally pulled down per SFF-8431 Rev4.1.
5. LOS is open collector output. Should be pulled up with 4.7k – 10kohms on host board to a voltage between 2.0V and 3.6V. Logic 0 indicates normal operation; logic 1 indicates loss of signal.
6. Internally connected

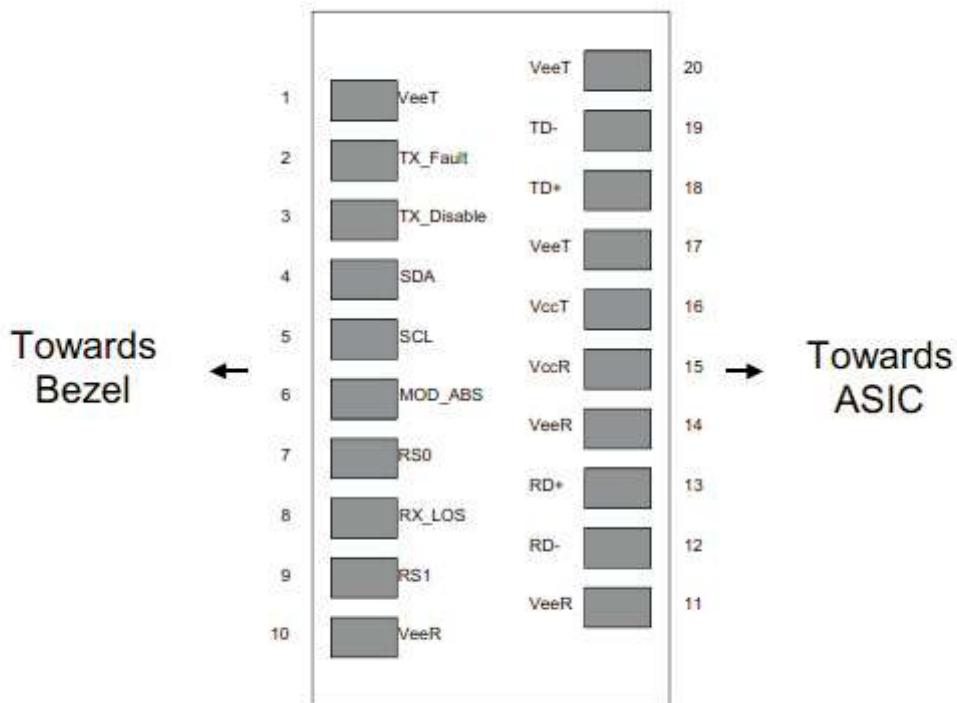

Pin-out of Connector Block on Host Board

## Recommend Circuit Schematic

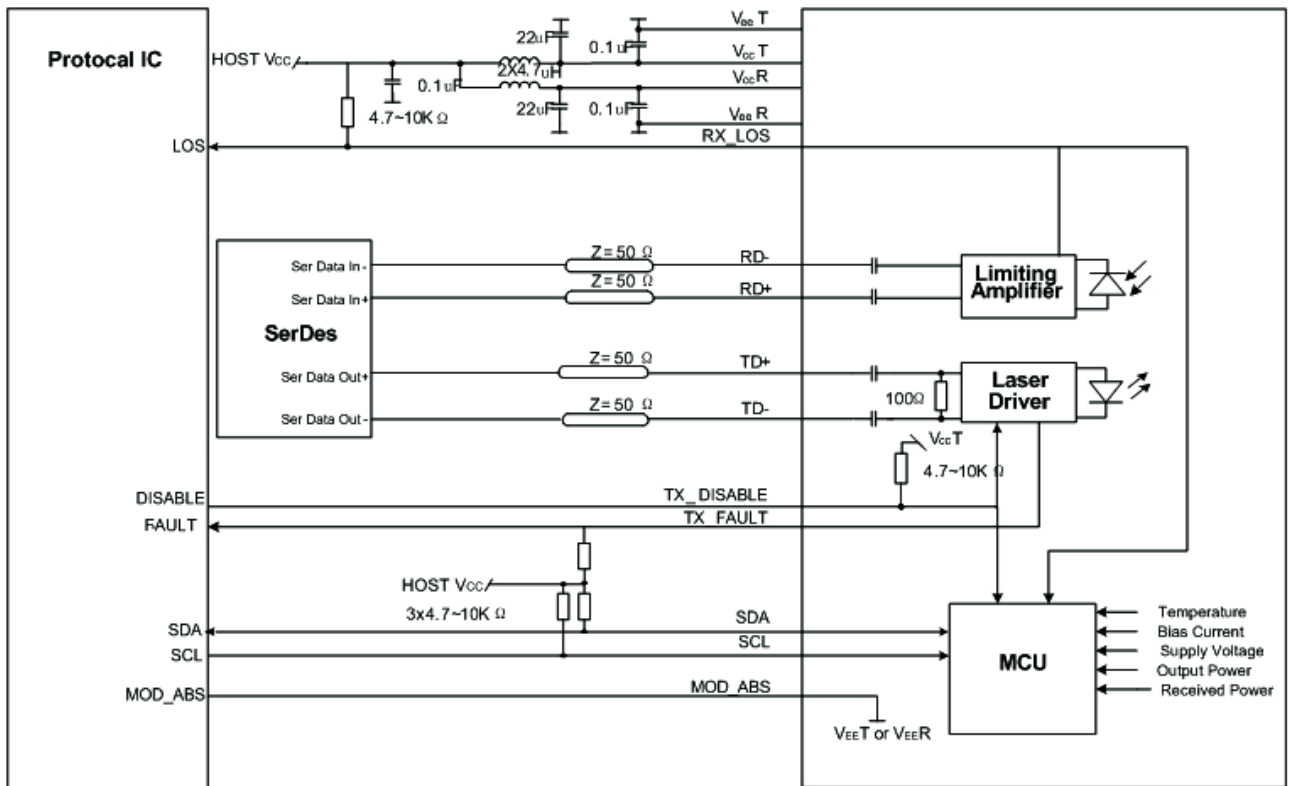

## Absolute Maximum Ratings

Parameter	Symbol	Min	Typ	Max	Unit	Ref.
Maximum Supply Voltage	Vcc	-0.5		+4.0	V	
Storage Temperature	TS	-40		+85	°C	
Operating Humidity	RH	0		85	%	

## Recommended Operating Conditions

Parameter	Symbol	Min	Typ	Max	Unit	Ref.
Power Supply Voltage	Vcc	3.13	3.30	3.47	V	
Power Supply Current	Icc			300	mA	Commercial
Case Operating Temperature	T	0		+70	°C	Commercial
Data Rate	BR		10.3		Gbps	
9/125um G.652 SMF	Lmax			20	km	

## Electrical Characteristics

Parameter	Symbol	Min	Typ	Max	Unit	Ref.
<b>Transmitter</b>						
Input differential impedance	Rin	80	100	120	Ω	1
Differential data input swing	Vin, pp	120		850	mV	
TX Disable-High		Vcc – 0.8		Vcc	V	
TX Disable-Low		Vee		Vee+ 0.8	V	
TX Fault-High		Vcc – 0.8		Vcc	V	
TX Fault-Low		Vee		Vee+ 0.8	V	
<b>Receiver</b>						
Differential data output swing	Vout, pp	300		850	mV	2
Data output rise time	Tr	28			ps	3
Data output fall time	Tf	28			ps	3
LOS-High		Vcc – 0.8		Vcc	V	
LOS-Low		Vee		Vee+0.8	V	

### Notes:

1. AC coupled.
2. Into 100 ohm differential termination.
3. 20 – 80 %

## Optical Characteristics

Parameter	Symbol	Min	Typ	Max	Unit	Ref.
<b>Transmitter</b>						
Output Opt. Power	PO	-5		+0.5	dBm	
Optical Wavelength	$\lambda$	x-6.5	x	x+6.5	nm	1
Side-Mode Suppression Ratio	SMSR	30			dB	
Spectral Width(-20dB)	$\Delta\lambda$			1	nm	
Optical Extinction Ratio	ER	3.5			dB	
<b>Receiver</b>						
RX Sensitivity @10.3Gb/s	SENS1			-14.4	dBm	2,3
Receiver Sensitivity (OMA) @ 10.3Gb/s	SENS2			-12.6	dBm	2,3
Receiver Overload		0.5			dBm	
Optical Center Wavelength	$\lambda_C$	1260		1610	nm	
LOS De-Assert	LOSD			-21	dBm	
LOS Assert	LOSA	-40			dBm	
LOS Hysteresis		0.5		5	dB	

### Notes:

- 1.The Transmitter Center Wavelength "x"=1271, 1291, 1311, 1331, 1351, 1371.
- 2.Measured with conformance signals defined in FC-PI-2 Rev. 10.0 specifications.
- 3.Measured with PRBS 2<sup>31</sup>-1 at 10<sup>-12</sup> BER.

## Mechanical Specifications

- ATOP's Small Form Factor Pluggable (SFP+) transceivers are compatible with the dimensions defined by the SFP Multi-Sourcing Agreement (MSA), dimensions are in mm.

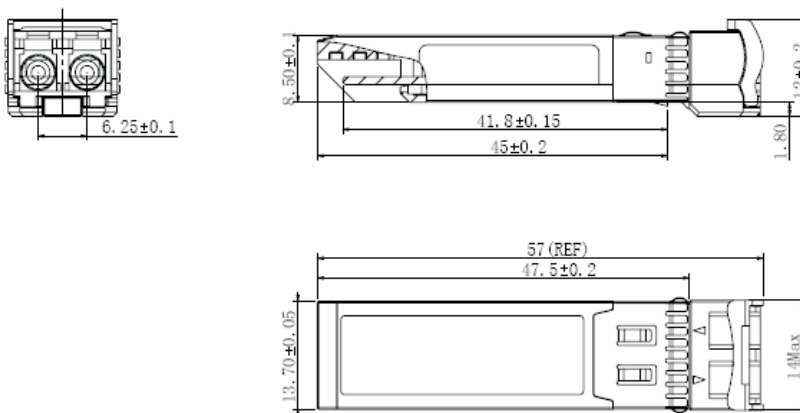

APSPCxxB33CDL20

## EEPROM Information

- EEPROM memory map specific data field description is as below:

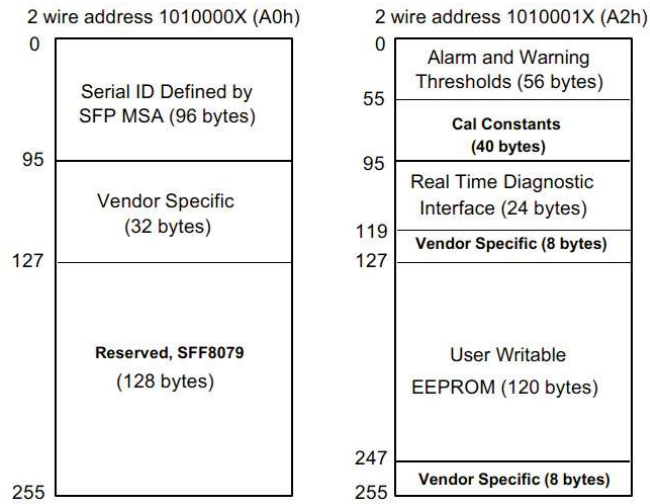

## Digital Diagnostic Monitoring Interface

Five transceiver parameter values are monitored. The following table defines the monitored parameter's accuracy.

Parameter	Range	Accuracy	Calibration
Temperature	0 to +70°C (C)	±3°C	Internal
Voltage	2.97 to 3.63V	±3%	Internal
Bias Current	0 to 100mA	±10%	Internal
TX Power	-5 to +0.5dBm	±3dB	Internal
RX Power	-14.4 to +0.5dBm	±3dB	Internal

## Revision History

Revision	Initiated	Reviewed	Approved	DCN	Release Date
Version1.0	Yangpeiyun	Sunbin	Ding zheng	New Released.	July 28, 2016
Version1.1	Tangzhiqiang	Yangpeiyun	Ding zheng	Update the new template	Dec 19, 2019





let's make it personal

[atoptechnology.com](https://atoptechnology.com)