



# SFP28 LAN WDM Transceiver

APS8LxxB5xDL10A



# SFP28 LAN WDM Transceiver

## APS8LxxB5xDL10A

ATOP's APS8LxxB5xDL10A single-mode transceiver is SFP28 module for duplex optical data communications support up to 25.78Gb/s. It is with the SFP+ 20-pin connector to allow hot plug capability. Digital diagnostic functions are available via an I<sup>2</sup>C. It has built-in clock and data recovery (CDR). This module is designed for single-mode fiber.

### Product Features

- ✓ Duplex LC connector
- ✓ Hot-pluggable SFP28 footprint
- ✓ Cooled LAN-WDM DFB laser
- ✓ RoHS compliant and Lead Free
- ✓ Distance up to 10km on 9/125um SMF
- ✓ Metal enclosure for lower EMI
- ✓ Power dissipation <2.3W
- ✓ Commercial / Industrial operating temperature optional

### Applications

- ✓ 25G Ethernet
- ✓ eCPRI & CPRI



## Product Selection

Part Number	Operating Case temperature	DDMI
APS8LxxB5CDL10A	Commercial (0~70°C)	Yes
APS8LxxB5IDL10A	Industrial(-40~85°C)	Yes

## Product Channel Selection

Part Number	Center Wavelength	Data Rate	Distance
APS8L69B5xDL10A	1269.23nm	25.78G	10KM
APS8L73B5xDL10A	1273.54nm	25.78G	10KM
APS8L77B5xDL10A	1277.89nm	25.78G	10KM

APS8L82B5xDL10A	1282.26nm	25.78G	10KM
APS8L86B5xDL10A	1286.66nm	25.78G	10KM
APS8L91B5xDL10A	1291.10nm	25.78G	10KM
APS8L95B5xDL10A	1295.56nm	25.78G	10KM
APS8L00B5xDL10A	1300.05nm	25.78G	10KM
APS8L04B5xDL10A	1304.58nm	25.78G	10KM
APS8L09B5xDL10A	1309.14nm	25.78G	10KM
APS8L13B5xDL10A	1313.73nm	25.78G	10KM
APS8L18B5xDL10A	1318.35nm	25.78G	10KM

## Regulatory Compliance

- ESD to the Electrical PINs: compatible with MIL-STD-883 Method 3015
- ESD to the Duplex LC Receptacle: compatible with EN 61000-4-2
- Immunity compatible with EN 61000-4-3
- EMI compatible with FCC Part 15 Class B
- Laser Eye Safety compatible with FDA 21CFR 1040.10 and 1040.11 IEC 60950, IEC60825-1,2
- RoHS compliant with RoHS 2.0(2015/863/EU)-amending

## Pin Descriptions

Pin	Symbol	Name	Ref.
1	VeeT	Transmitter Ground (Common with Receiver Ground)	1
2	TX Fault	Transmitter Fault. LVTTTL-O	2
3	TX Disable	Transmitter Disable. Laser output disabled on high or open. LVTTTL-I	3
4	SDA	2-Wire Serial Interface Data Line (Same as MOD-DEF2 in INF-8074i). LVTTTL-I/O	2
5	SCL	2-Wire Serial Interface Data Line (Same as MOD-DEF2 in INF-8074i). LVTTTL-I	2
6	Mod_ ABS	Module Absent, Connect to VeeT or VeeR in Module.	2
7	RS0	Rate Select 0, optionally controls SFP+ module receiver . LVTTTL-I	4
8	LOS	Loss of Signal indication. Logic 0 indicates normal operation. LVTTTL-O	5
9	RS1	Rate Select 1, optionally controls SFP+ module transmitter. LVTTTL-I	4
10	VeeR	Receiver Ground (Common with Transmitter Ground)	1
11	VeeR	Receiver Ground (Common with Transmitter Ground)	1
12	RD-	Receiver Inverted DATA out. AC Coupled. CML-O	
13	RD+	Receiver Non-inverted DATA out. AC Coupled. CML-O	
14	VeeR	Receiver Ground (Common with Transmitter Ground)	1
15	VccR	Receiver Power Supply	6
16	VccT	Transmitter Power Supply	6
17	VeeT	Transmitter Ground (Common with Receiver Ground)	1
18	TD+	Transmitter Non-Inverted DATA in. AC Coupled. CML- I	
19	TD-	Transmitter Inverted DATA in. AC Coupled. CML- I	
20	VeeT	Transmitter Ground (Common with Receiver Ground)	1

## Note

1. Circuit ground is internally isolated from chassis ground.
2. TX Fault is an open collector/drain output .Which should be pulled up with a 4.7K – 10K Ohms resistor on the host board if intended for use. Pull up voltage should be between 2.0V to Vcc+0.3V.A high output indicates a transmitter fault caused by either the tx bias current or the tx output power exceeding the preset alarm thresholds. A low output indicates normal operation .In the low state, the output is pulled to <0.8V.
3. Laser output disabled on TX Disable >2.0V or open, enabled on TX Disable<0.8V.
4. Internally pulled down per SFF-8431 Rev4.1.
5. LOS is open collector output. Should be pulled up with 4.7k – 10kohms on host board to a voltage between 2.0V and 3.6V. Logic 0 indicates normal operation; logic 1 indicates loss of signal.
6. Internally connected.

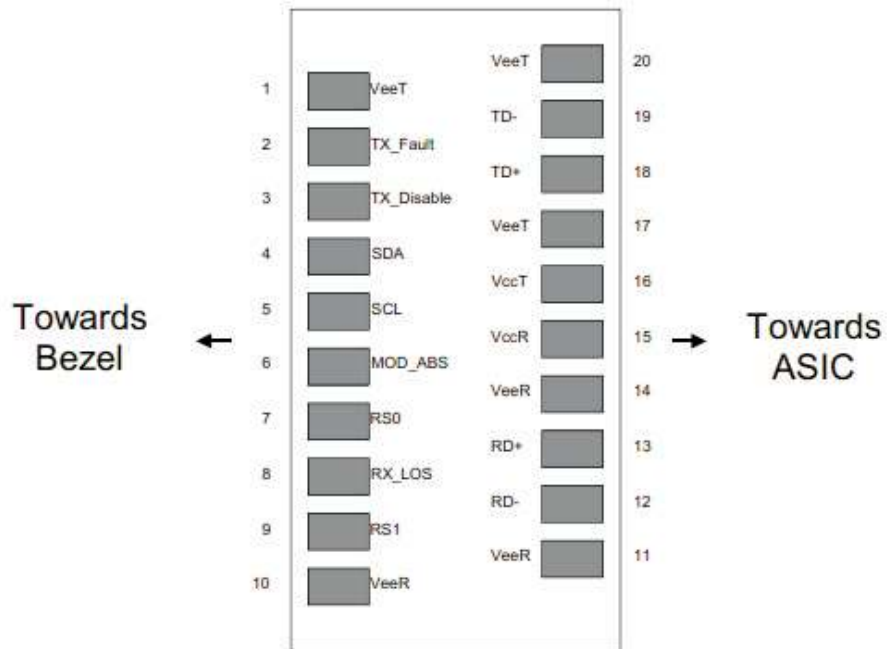

Pin-out of Connector Block on Host Board

Recommend Circuit Schematic

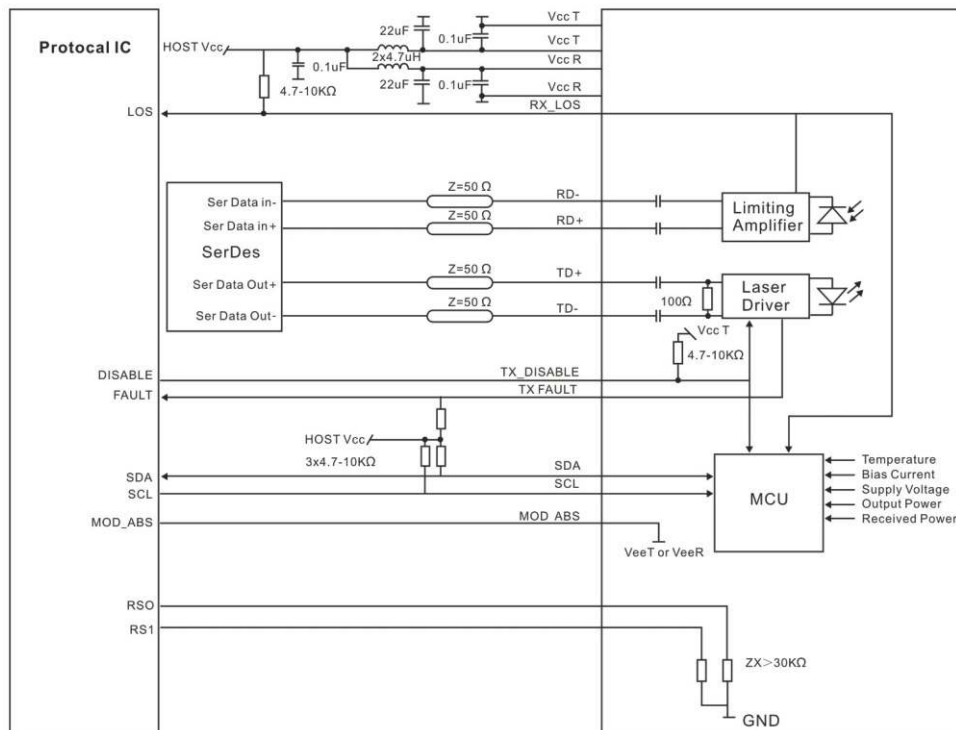

## Absolute Maximum Ratings

Parameter	Symbol	Min	Typ	Max	Unit	Ref.
Maximum Supply Voltage	Vcc	-0.5		+4.0	V	
Storage Temperature	TS	-40		+85	°C	
Operating Humidity	RH	0		85	%	

## Recommended Operating Conditions

Parameter	Symbol	Min	Typ	Max	Unit	Ref.
Power Supply Voltage	Vcc	3.13	3.30	3.47	V	
Power Supply Current	Icc			690	mA	
Case Operating Temperature	Tc	0		+70	°C	Commercial
	Ti	-40		+85	°C	Industrial
Data Rate	BR		25.78		Gbps	
9/125um G.652 SMF	Lmax			10	km	

## Electrical Characteristics

Parameter	Symbol	Min	Typ	Max	Unit	Ref.
<b>Transmitter</b>						
Input differential impedance	Rin	80	100	120	Ω	1
Differential data input swing	Vin, pp	90		800	mV	
TX Disable-High		Vcc - 1.3		Vcc+ 0.3	V	
TX Disable-Low		Vee		Vee+ 0.8	V	
TX Fault-High		Vcc-1.3		Vcc+ 0.3	V	
TX Fault-Low		Vee		Vee+0.8	V	
<b>Receiver</b>						
Differential data output swing	Vout, pp	185		425	mV	2
LOS-High		Vcc-1.3		Vcc+ 0.3	V	
LOS-Low		Vee		Vee+0.8	V	

### Notes:

1. AC coupled.
2. Into 100 ohm differential termination.

## Optical Characteristics

Parameter	Symbol	Min	Typ	Max	Unit	Ref.
<b>Transmitter</b>						
Output Opt. Power	PO	0		+6	dBm	
Output Opt. Power OMA	$P_{OMA}$	0.5			dBm	
Optical Wavelength	$\lambda$	$\lambda-1$	$\lambda$	$\lambda+1$	nm	
Spectral Width(-20dB)	$\Delta\lambda$			1	nm	
Optical Extinction Ratio	ER	3.5			dB	
Dispersion penalty@10km fiber	DP			1.5	dB	
Side-Mode Suppression Ratio	SMSR	35			dB	
<b>Receiver</b>						
RX Sensitivity	SEN			-14	dBm	1
Receiver Overload		+2			dBm	1
Optical Center Wavelength	$\lambda_C$	1250		1620	dBm	
LOS De-Assert	LOSD			-15	dBm	
LOS Assert	LOSA	-35			dBm	
LOS Hysteresis		0.5		6	dB	

### Notes:

1. Measured with data rate at 25.78Gb/s, BER less than  $5E-5$  with PRBS  $2^{31}-1$ .

## Mechanical Specifications

- ATOP's Small Form Factor Pluggable (SFP28) transceivers are compatible with the dimensions defined by the SFP Multi-Sourcing Agreement (MSA) , dimensions are in mm.

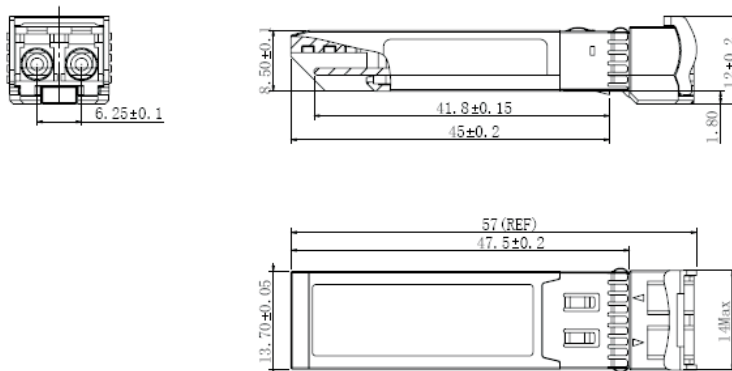

APS8LxxB5xDL10A

## EEPROM Information

- EEPROM memory map specific data field description is as below:

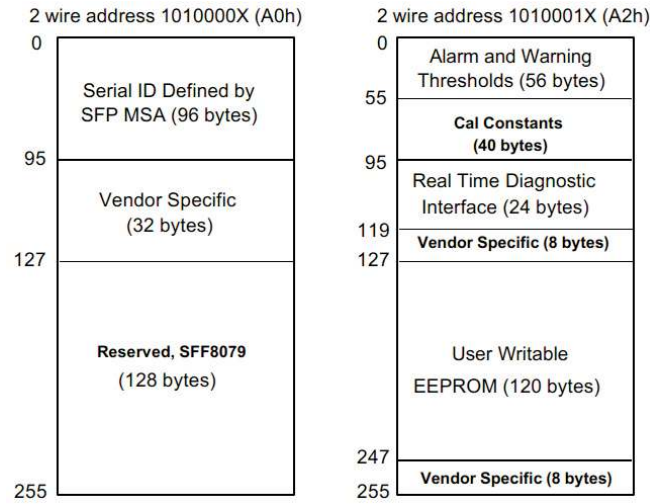

## Digital Diagnostic Monitoring Interface

Five transceiver parameter values are monitored. The following table defines the monitored parameter's accuracy.

Parameter	Range	Accuracy	Calibration
Temperature	-40 to +85°C (I)	±3°C	Internal
Voltage	2.97 to 3.63V	±3%	Internal
Bias Current	0 to 80mA	±10%	Internal
TX Power	0 to +6dBm	±3dB	Internal
RX Power	-14 to +2dBm	±3dB	Internal

## Revision History

Revision	Initiated	Reviewed	Approved	DCN	Release Date
Version1.0	Tang Zhiqiang	Xiong Weilin	Ding Zheng	New Released.	Jan 15, 2019
Version1.1	Tang Zhiqiang	Xiong Weilin	Ding Zheng	Update the new template	July 16, 2020





let's make it personal

[www.atoptechnology.com](http://www.atoptechnology.com)